



AR 26

Loosening, separating, transporting



The greats among the small: AR 26

Optimum economic and technical results can be achieved with the right external vibrator for the filling, compaction, transporting and sifting of bulk goods. Wacker Neuson's external vibrators are always the right choice, particularly for the use in silos or with conveyors and sifting technology.

- Long staying power thanks to its powerful electric motor with stable speeds.
- Powerful and reliable performance
- Variable centrifugal force through removal or rotation of the eccentric weight discs
- Vibration resistant design
- Small, compact and light.

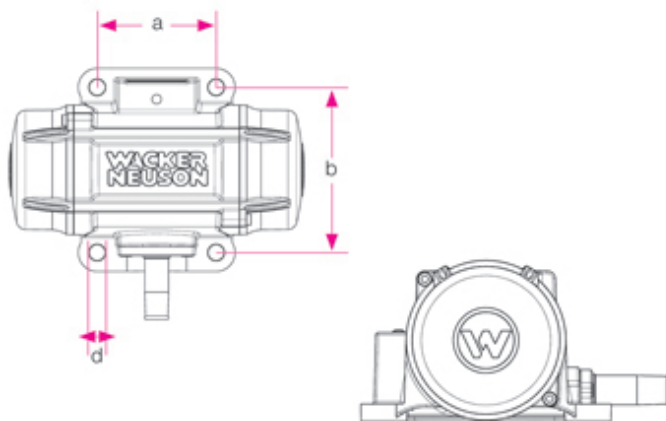

	d mm	a mm	b mm
AR/ARFU 26			
AR 36	11	90	125
AR 43			
AR 53	18	90	154
AR 34			
AR 54	17,5	120	120
AR 64			
AR 75	17	95	180



Technical specifications

	AR 26/3/400	AR 26/3,6/230	AR 26/3/230 w
Vibrations rpm	3,000	3,600	3,000
Centrifugal force max. kN	3	3.47	3
Rated voltage 3~ V	400	230	230
Rated current A	0.57	1.1	1.75
Weight kg	6.2	5.5	7
Fastening	90 x 125		90 x 125

Please note

that product availability can vary from country to country. It is possible that information / products may not be available in your country. More detailed information on engine power can be found in the operator's manual; the stated power may vary due to specific operating conditions.

Subject to alterations and errors excepted. Applicable also to illustrations.

Copyright © 2015 Wacker Neuson SE.